QUEENSLAND PLUMBING AND WASTEWATER CODE

Table of Contents

Interpretation	1
Objective and Functional Statements.....	2
Definitions	2
Part 1 – <i>On-site wastewater management systems</i>	6
Part 2 – <i>Greywater use facilities</i>	7
Part 3 – <i>Land application systems</i>	8
Part 4 – <i>Water meters for new premises</i>	9
Part 5 – Chief Executive Approvals	10
Part 6 – Non <i>certified</i> testable backflow prevention devices for fire service	17
Part 7 – New and replacement electric hot water systems.....	21
Part 8 – Water conservation for <i>class 1</i> and <i>class 2</i> buildings	22
Part 9 – Chief Executive Approval for <i>Blackwater</i> Trials in Southeast Queensland .	23

Interpretation

The Queensland Plumbing and Wastewater Code (QPW code) has been designed to provide performance solutions to meet the statutory requirements of the *Plumbing and Drainage Act 2002*. This will maintain the standards set by the QPW code while allowing for innovation in materials and methods.

Objectives and Functional Statements are informative only and are included to provide an aid to interpreting the Performance Criteria. Objectives are the community expectations for the QPW code. Functional Statements describe how to meet those community expectations.

Performance Criteria have been developed to meet the Objectives and Functional Statements. The Acceptable Solutions provide a simple and direct manner of meeting the Performance Criteria.

Where legislation requires compliance with the QPW code, compliance with the Performance Criteria is mandatory.¹

Unless otherwise provided by the QPW code, the requirements of the relevant Australian and New Zealand Standards are applicable². Where there is any inconsistency, or the QPW code has additional requirements, the QPW code prevails.

¹ Section 8B of the *Standard Plumbing and Drainage Regulation 2003* provides:

8B Compliance with QPW code

- (1) Plumbing and drainage work and *on-site sewerage work* must comply with the QPW code.
- (2) Plumbing and drainage work or *on-site sewerage work* complies with the QPW code only if the work satisfies the relevant performance criteria under the QPW code.
- (3) Compliance with the relevant performance criteria can be achieved only by—
 - (a) complying with the relevant acceptable solution under the QPW code; or
 - (b) formulating an alternative solution that—
 - (i) satisfies the performance criteria; and
 - (ii) is shown to be at least equivalent to the relevant acceptable solution under the QPW code; or
 - (c) a combination of paragraphs (a) and (b).

The Australian / New Zealand Standards referred to in the QPW code, are taken to apply to all *on-site wastewater management systems* and *greywater use facilities* assessed under the *Plumbing and Drainage Act 2002* regardless of the limitations expressed in the relevant standard.³

Objective and Functional Statements

The QPW code adopts the Objective, Functional Statement and Verification Methods of Part F1 of the Plumbing Code of Australia.

Definitions

Unless noted otherwise, all terms have the same meaning as defined in the *Plumbing and Drainage Act 2002*, *Standard Plumbing and Drainage Regulation 2003* or a relevant Australian/New Zealand Standard.⁴

If a definition given in a relevant standard is inconsistent with the Act, Regulation or the QPW code, the legislation (i.e. the Act or Regulation) prevails as to the extent of the inconsistency.

Note: *Italicised* words within the body of the text, other than legislation titles, are defined below.

amenity means an attribute which contributes to the health, physical independence, comfort and well being of people.

apparatus for supplying water to premises, includes a *water meter*.

applied provisions has the meaning provided in Schedule 1 of the *Standard Plumbing and Drainage Regulation 2003*.

automatic switching device controls the *water supply* to plumbing outlets by automatically switching from *rainwater tank* water to the *water service* when the water level in the *rainwater tank* is insufficient to meet household demand.

blackwater is defined as:

- (a) the waste discharged from the human body into a toilet, and
- (b) the water used for the discharge.

certified means a plumbing or drainage product approved by a Conformity Assessment Body (CAB) in accordance with the *Product code authorisation and certification*.

classes 1,2,4,5,6,7, 8 and 9, in relation to a building, mean the definitions as specified in Part A3.2 of Volume One of the Building Code of Australia.

common area means an area of *common property*.

common bathroom means the most, or what is expected to be the most, frequently used bathroom of the building.

² *Standard Plumbing and Drainage Regulation 2003* s 9 requires compliance with Australian and New Zealand Standards 3500.0 to .2 and .4 and 1546.1 and .3 and 1547

³ Example: the definitions of design loading rate and design irrigation rate are separately defined in AS/NZ 1547 (On-site domestic-wastewater management). This standard is an “*applied provision*” under the *Standard Plumbing and Drainage Regulation 2003* and therefore applies to the interpretation of the QPW Code.

⁴ Example: the definitions of design loading rate and design irrigation rate are separately defined in AS/NZS 1547 (On-site domestic-wastewater management). This standard is an “*applied provision*” under the *Standard Plumbing and Drainage Regulation 2003* and therefore applies to the interpretation of the QPW code.

common property has the meaning provided in section 10 of the *Body Corporate and Community Management Act 1997*.

complying valve means a device incorporated as part of the *water meter* which a *water service provider* can use to securely restrict the flow of water, either partially or fully, to the *meterable premises*, installed upstream of a *water meter*.

community titles scheme see section 10 of the *Body Corporate and Community Management Act 1997*.

design life means the period during which the item is designed to meet the performance criteria. It is to be a minimum of 15 years.

dry-vault toilet a toilet which is not a chemical, composting or incinerating toilet.

efficient irrigation system means a fixed *outdoor irrigation system* consisting of a network of permanent piping connected to *emitters* which has been designed and installed to water a specific landscape area and reduce the maximum output capacity.

emitter means a device of any kind fitted on a pipe which is operated under pressure to discharge water in a spray, mist or drip form. Common types of *emitters* include drippers, micro-sprayers, pop-up and gear-drive sprays and fixed sprinkler heads.

existing hot water system means a hot water system in a *class 1* building located within a *gas reticulated area*.

gas reticulation area means an area determined by the gas network distributor where the distributor advises the hot water system installer that natural reticulated gas can be supplied to the property's gas meter at no cost to the building owner.

greywater means wastewater from a bath, basin, kitchen, laundry or shower, whether or not the wastewater is contaminated with human waste.

greywater application area means an area in which *greywater* is disposed of by subsurface or surface irrigation.

greywater diversion device—

1. A *greywater diversion device* is a device that consists of—
 - (a) a diversion device with the characteristics mentioned in paragraph 2; and
 - (b) a filtering system that uses a coarse filter to remove solids from *greywater*.
2. For paragraph 1, the characteristics are that the device—
 - (a) directs and diverts *greywater* to sanitary drainage or a *greywater application area*; and
 - (b) automatically diverts *greywater* from the facility to sanitary drainage if the facility does not work properly or at all; and
 - (c) allows the manual diversion of *greywater* from the facility to sanitary drainage.

greywater treatment plant means a treatment *plant* installed on premises for treating, on the premises in a day, not more than 50kL of *greywater* generated on the premises.

greywater use facility means a facility that consists of—

- (a) a *greywater diversion device* and a *greywater application area*; or
- (b) a *greywater treatment plant* and a *greywater application area*; or
- (c) a *greywater treatment plant*.

land application area means an area in which effluent from an *on-site sewage treatment plant*, *greywater treatment plant* or *greywater diversion device* is disposed of by subsurface or surface irrigation.

land application system means a *greywater application area* associated with a *greywater use facility* or a *land application area* associated with an *on-site sewerage facility*.

meterable premises means:

- (a) all *class 1* buildings; and
- (b) each lot within a *community title scheme*, including the *common property*, in a *water service provider's area*; and
- (c) the *sole-occupancy unit* of a *class 2, 4, 5, 6, 7 or 8* building in a *water service provider's area*; and
- (d) each *storey* of a *class 5* building in a *water service provider's area* where the building consists of more than one *storey* and *sole-occupancy units* are not identified at the time of the building's plumbing compliance assessment.

new class 1 building means a *class 1* building for which a request for compliance assessment is made under the *Plumbing and Drainage Act 2002* irrespective of when the relevant building development application is approved and does not include *class 1* buildings which have an *existing hot water system* installed.

on-site sewage treatment plant is a sewage treatment *plant* installed or to be installed on premises as part of an *on-site sewerage facility* for the premises.

on-site sewerage facility means:

a facility, other than an environmentally relevant *on-site sewerage facility* or a *dry-vault toilet*, installed on premises for—

- (a) treating, on the premises, sewage generated on the premises, and disposing of the resulting effluent—
 - (i) on part of the premises (commonly called a '*land application area*'); or
 - (ii) off the premises by common effluent drainage or by collection from a tank on the premises; or
- (b) storing on the premises sewage generated on the premises for its subsequent disposal off the premises by collection from the premises; or
- (c) chemically treating, composting or incinerating toilet waste.

on-site sewerage work means building, installing or changing an *on-site sewerage facility*, including, for example, building, installing or changing an *on-site sewerage facility* for testing purposes.

on-site wastewater management system means a system installed on premises that receives and treats wastewater generated on the premises and applies the resulting effluent to an approved disposal or *land application area* (including an *on-site sewerage facility* but excluding a *greywater use facility*).

outdoor irrigation system means a network of permanent piping connected to *emitters* which has been designed and installed to water a specific landscape area.

plant means an *on-site sewage treatment plant* or a *greywater treatment plant*.

public area means an area to which the public has lawful access - for example, a footpath.

product code authorisation and certification means production authorisation and certification under the document in force from time to time called 'Plumbing Code of Australia', produced for all State Governments by the National Plumbing Regulators Forum.

rainwater tank means a covered tank or combination of covered tanks used to collect rainwater from a building roof.

replacement hot water system means a hot water system that –

- (a) replaces an *existing hot water system*; and

(b) complies with performance criterion 1 of Part 7.

sole-occupancy unit, in relation to a building, means—

- (a) means a room or other part of the building for occupation by one or a joint owner, lessee, tenant, or other occupier to the exclusion of any other owner, lessee, tenant, or other occupier, including, for example—
 - (i) a dwelling; or
 - (ii) a room or suite of associated rooms in a building classified under the Building Code of Australia as a *class 2, 4, 5, 6, 7 or 8* building; or
- (b) any part of the building that is a *common area* or *common property*.

storey means a space within a building which is situated between one floor level and the floor level next above, or if there is no floor above, the ceiling or roof above, but not—

- (a) a space that contains only—
 - (i) a lift shaft, stairway or meter room; or
 - (ii) a bathroom, shower room, laundry, water closet, or sanitary compartment; or
 - (iii) accommodation intended for not more than 3 vehicles; or
 - (iv) a combination of the above; or
- (b) a mezzanine.

temporary hot water system means a hot water system that maintains supply of hot water to the household during the installation of the *replacement hot water system*.

trickle top-up system means a system that provides an approved plumbing connection between the *water service* and a *rainwater tank* in accordance with AS/NZS 3500.1:2003.

water meter means a device, including equipment related to the device, for measuring the volume of water supplied to premises.

Example of equipment related to the device— a pulse meter associated with the device.

water supply means the plumbing supplying water to *meterable premises* from a *water service*.

water service has the same meaning as provided in the *Water Supply (Safety and Reliability) Act 2008*.

water service provider, for premises, means the person registered under the *Water Supply (Safety and Reliability) Act 2008*, chapter 2, part 3, as the *water service provider* for retail *water services* for the premises.

Part 1 – On-site wastewater management systems

	PERFORMANCE CRITERIA		ACCEPTABLE SOLUTIONS
P1	<p><i>On-site wastewater management systems</i> must be designed, constructed, installed and maintained in such a manner as to—</p> <ul style="list-style-type: none"> (a) protect public health by ensuring that risks associated with the dispersal of wastewater to the <i>land application area</i> are minimised; and (b) protect the environment by ensuring— <ul style="list-style-type: none"> (i) surface and ground water are not polluted; (ii) soil productivity is maintained or enhanced; and (c) minimise the impacts on and maintain and enhance <i>amenity</i> by ensuring it has no adverse impact on— <ul style="list-style-type: none"> (i) the built environment; and (ii) persons on and nearby the premises, for the <i>design life</i> of the facility. 	A1	<ul style="list-style-type: none"> (a) Wastewater must be disposed of in a <i>land application area</i> which complies with Part 3 of the QPW code; and (b) The <i>on-site wastewater management system</i> otherwise complies with the <i>applied provisions</i>; and (c) The <i>on-site wastewater management system</i> must be operated and maintained in accordance with the designer's or manufacturer's instructions.
P2	<p><i>On-site wastewater management systems</i> that facilitate on-site storage, treatment, disposal or re-use of wastewater must be designed, constructed and installed—</p> <ul style="list-style-type: none"> (a) with adequate treatment and storage capacity for the volume of waste and frequency of disposal; (b) with adequate size, strength and rigidity for the nature, flow rates, volume of wastes and/or waste products which must be processed; (c) with adequate vehicle access for collection, if required; (d) to avoid the likelihood of contamination of any drinking water supplies; (e) to avoid the likelihood of contamination of soils, ground water and waterways; (f) from materials which are impervious both to the waste for which disposal is required and to water; (g) to avoid the likelihood of foul air and gases accumulating within or entering into buildings; (h) to avoid the likelihood of unauthorised access by people; (i) to permit cleaning, maintenance, measurement and performance sampling; (j) to avoid the likelihood of surface water and stormwater entering the system; (k) to avoid the likelihood of uncontrolled discharge; (l) to permit the manufacturer, model, serial number and designed capacity to be reasonably easily identifiable after installation; (m) to minimise nuisance eg noise to the occupants of neighbouring properties; and (n) so that the installation throughout its <i>design life</i> will continue to satisfy the requirements of items (a) to (m). 	A2	<ul style="list-style-type: none"> (a) The size determination, design and installation of septic tanks must be in accordance with AS/NZS 1546.1; and (b) The size determination, design and installation of aerated wastewater treatment systems must be in accordance with AS/NZS 1546.3; and (c) The design, construction, installation, replacement, repair, alteration and maintenance of all sanitary plumbing and drainage systems must be in accordance with AS/NZS 3500.2; and (d) The management of <i>on-site wastewater management systems</i> must be in accordance with AS/NZS 1547.

Part 2 – Greywater use facilities

	PERFORMANCE CRITERIA		ACCEPTABLE SOLUTIONS
P1	<p>A <i>greywater use facility</i> must be designed, constructed, installed and maintained in such a manner as to—</p> <p>(a) protect public health by ensuring that risks associated with the use and/or dispersal of <i>greywater</i> to the <i>greywater application area</i> are minimised; and</p> <p>(b) protect the environment by ensuring—</p> <p>(i) surface and ground water are not polluted; and</p> <p>(ii) soil productivity is maintained or enhanced; and</p> <p>(c) minimise the impacts on and maintain and enhance the <i>amenity</i> by ensuring it has no adverse impact on—</p> <p>(i) the built environment; and</p> <p>(ii) persons on and nearby the premises,</p> <p>for the <i>design life</i> of the facility.</p>	A1	<p>(a) Either -</p> <p>(i) <i>greywater</i> is disposed of in a manner appropriate for its potential end use as listed in Table T1A or T1B; or</p> <p>(ii) where <i>greywater</i> is disposed of to a <i>land application area</i>, it complies with Part 3 of the QPW code; and</p> <p>(b) The <i>greywater use facility</i> otherwise complies with the <i>applied provisions</i>; and</p> <p>(c) The <i>greywater use facility</i> must be operated and maintained in accordance with the designer's or manufacturer's instructions.</p>
P2	<p>A <i>greywater use facility</i> must be designed, constructed and installed—</p> <p>(a) with adequate treatment and storage capacity for the volume of waste and frequency of disposal;</p> <p>(b) with adequate size, strength and rigidity for the nature, flow rates, volume of wastes and/or waste products which must be processed;</p> <p>(c) with adequate vehicle access for collection, if required;</p> <p>(d) to avoid the likelihood of contamination of any drinking water supplies;</p> <p>(e) to avoid the likelihood of contamination of soils, ground water and waterways;</p> <p>(f) from materials which are impervious both to the waste for which disposal is required and to water;</p> <p>(g) to avoid the likelihood of foul air and gases accumulating within or entering into buildings;</p> <p>(h) to avoid the likelihood of unauthorised access by people;</p> <p>(i) to permit cleaning, maintenance, measurement and performance sampling;</p> <p>(j) to avoid the likelihood of surface water and stormwater entering the system;</p> <p>(k) to avoid the likelihood of uncontrolled discharge;</p> <p>(l) to permit the manufacturer, model, serial number and designed capacity to be reasonably easily identifiable after installation;</p> <p>(m) to minimise nuisance eg noise to the occupants of neighbouring properties; and</p> <p>(n) so that the installation throughout its <i>design life</i> will continue to satisfy the requirements of items (a) to (m).</p>	A2	<p>(a) Design, construction and installation of a <i>greywater use facility</i> must be in accordance with AS/NZS 1547 and AS/NZS 3500: with necessary modifications as appropriate; and</p> <p>(b) The design of a <i>greywater treatment plant</i> must ensure that the volume of treated <i>greywater</i> available for any indoor use be equivalent to three days supply for the indoor use; and</p> <p>(c) <i>Greywater treatment plants</i> must be designed to provide at least 36 hours retention for the expected daily flow of <i>greywater</i>, with 40 litres/person/year of capacity allowed for scum and sludge accumulation.</p>

Part 3 – Land application systems

	PERFORMANCE CRITERIA		ACCEPTABLE SOLUTIONS
P1	<p>A <i>land application system</i> must be designed constructed, installed and maintained in such a manner as to—</p> <ul style="list-style-type: none"> (a) complete the treatment, uptake and absorption of the final effluent within the boundaries of the approved application area; (b) avoid the likelihood of the creation of unpleasant odours or the accumulation of offensive matter; (c) avoid the likelihood of the ingress of effluent, foul air or gases entering buildings; (d) avoid the likelihood of stormwater run-off entering the system; (e) avoid the likelihood of root penetration or ingress of ground water entering the system; (f) protect against internal contamination; (g) provide adequate access for maintenance; (h) incorporate adequate provisions for effective cleaning; (i) avoid the likelihood of unintended or uncontrolled discharge; (j) avoid the likelihood of blockage and leakage; (k) avoid the likelihood of damage from superimposed loads or ground movement; (l) provide ventilation to avoid the likelihood of foul air and gases from accumulating in the system; (m) minimise nuisance eg noise to the occupants of neighbouring properties; and (n) ensure that the installation throughout its <i>design life</i> will continue to satisfy the requirements of items (a) to (m). 	A1	<ol style="list-style-type: none"> 1. The <i>land application system</i> complies with each of clauses (a) and (b) in determining the size and position of the <i>land application system</i> while taking into account the written report (and any photographic material) produced as a result of an on-site inspection carried out in accordance with Clause 4.1.3.4(b) of AS/NZS 1547— <ul style="list-style-type: none"> (a) The setback distances specified in: <ul style="list-style-type: none"> (i) Table T4 for a subsurface <i>land application system</i> from a <i>greywater treatment plant</i> or an <i>on-site sewage treatment plant</i>. (ii) Table T5 for a surface irrigated <i>land application system</i> from a <i>greywater treatment plant</i> or an <i>on-site sewage treatment plant</i>. (iii) Table T6 for a <i>greywater diversion device</i>. (iv) Table T7 for an <i>on-site sewerage facility</i> and all <i>greywater use facilities</i>. (b) The following sub clauses: <ul style="list-style-type: none"> (i) the design irrigation rate or design loading rate is to be appropriate to the characteristics of the terrain and soil in and near the <i>land application area</i>, and (ii) the environmental constraints and the anticipated daily volume of <i>greywater</i> in <i>Table T2</i> for sewerred areas and <i>Table T3</i> for unsewered areas. 2. The <i>land application area</i> and any pump or motor are not located adjacent to bedrooms, living rooms or recreational areas of the premises or neighbouring properties.

Part 4 – *Water meters* for new premises

	PERFORMANCE CRITERIA		ACCEPTABLE SOLUTIONS
P1	The <i>water supply</i> to a <i>meterable premises</i> must be fitted with a device (<i>water meter</i>) to measure the amount of water supplied to the premises.	A1	Each <i>water supply</i> to a <i>meterable premises</i> is to be fitted with a <i>water meter</i> which— (a) measures only the water supplied by that <i>water supply</i> to that <i>meterable premises</i> ; and (b) is approved by the <i>water service provider</i> ; and (c) complies with relevant requirements of the <i>water service provider</i> that may be imposed under the <i>Water Supply (Safety and Reliability) Act 2008</i> .
P2	A <i>water meter</i> must be located so it is easy to read and maintain.	A2	The <i>water meter</i> is located— (a) so that it can be easily maintained and read from a <i>common area</i> , <i>common property</i> or <i>public area</i> ; and (b) it is installed— (i) in a <i>common area</i> ; or (ii) in <i>common property</i> ; or (iii) less than 3m from a property boundary within a <i>public area</i> .
P3	A <i>water meter</i> must be properly maintained.	A3	A <i>water meter</i> is to be maintained in accordance with the relevant Australian Standards ⁵ .
P4	The installation of a <i>water meter</i> includes a device which allows for the restriction of the flow of water from the <i>water service</i> to the <i>water meter</i> .	A4	The <i>water meter</i> has a <i>complying valve</i> .

⁵ AS3565.1:2004 Meters for *Water Supply* – Cold *water meter*
 AS3565.2:2004 Meters for *Water Supply* – Combination Meters
 AS3565.3:2004 Meters for *Water Supply* – *Water meters* with integral dual check valves
 AS3565.4:2004 Meters for *Water Supply* – In-service compliance testing
 AS3565.5:2004 Meters for *Water Supply* – *Water meters* with two integral single check valves

Part 5 – Chief Executive Approvals

This Part establishes the requirements for a Chief Executive Approval of an *on-site sewage treatment plant* or a *greywater treatment plant* under section 91 of the *Plumbing and Drainage Act 2002*.

A Chief Executive Approval is required:

- a) for an *on-site sewage treatment plant* where the sewage generated on the property is less than that of 21 equivalent persons; or
- b) for a *greywater treatment plant* where the treated *greywater* is less than 50kL per day⁶.

A Chief Executive Approval does not include:

- a) the method of land application of the treated effluent; or
- b) a chemical, composting or incinerating toilet; or
- c) a *dry-vault toilet* (e.g. waterless toilet).

Testing Agency

All compliance checking, monitoring, testing, and sampling is to be performed by an agency accredited as a third party quality management certification body *certified* by the Joint Accreditation System of Australia and New Zealand (JAS-ANZ) or by another accreditation body with which JAS-ANZ has a memorandum of understanding, and at the cost of the applicant.

The samples for Biochemical Oxygen Demand (BOD), suspended solids, total nitrogen, total phosphorus and thermotolerant coliforms, taken by the testing agency, must be directly transported and delivered to a laboratory, registered by the National Association of Testing Authorities (NATA) to carry out analyses for the parameters specified. Where applicable, residual disinfectant and dissolved oxygen samples must be analysed on-site. The test criteria and test period procedures specified in Appendix A of AS/NZS 1546.3 apply to an *on-site sewage treatment plant* placed under test.

Performance Evaluation Testing – Other than AS/NZS 1546.3

Where AS/NZS 1546.3:2001 does not apply then performance evaluation testing may be carried out in accordance with Appendix 2.

For example, this will be the case where the number of equivalent persons generating waste exceeds 10. It may also occur where it is difficult or not possible to construct the *on-site sewage treatment plant* (e.g. a sand filter) or test the *plant* at a Municipal Treatment Plant (e.g. a *greywater treatment plant*).

⁶ The Department of Environment and Resource Management will assess applications (on a case by case basis) for premises generating *greywater* greater than 50kL per day.

Performance criteria for Chief Executive Approvals

	PERFORMANCE CRITERIA		ACCEPTABLE SOLUTIONS
P1	<p>The <i>plant</i> is designed and capable of being tested to ensure to ensure that—</p> <ul style="list-style-type: none"> (a) all <i>plant</i> discharges are safe; and (b) risks associated with the discharge of human waste and domestic-wastewater to the environment are minimised; and (c) surface and groundwater are not polluted; and (d) soil productivity is maintained or enhanced, and cumulative adverse environmental effects do not occur during the <i>design life</i>. 	A1	<p>The <i>plant</i>—</p> <ul style="list-style-type: none"> (a) which is an <i>on-site sewage treatment plant</i> meets the Effluent Quality requirements in Appendix 1; or (b) which is a <i>greywater treatment plant</i> that produces outputs equivalent to the Potential End Uses in Table T1A or T1B.
P2	<p>The <i>plant</i> is designed to maintain and enhance community <i>amenity</i> by—</p> <ul style="list-style-type: none"> (a) being managed so as to achieve sustainable long-term performance; and (b) provides treatment capacity to meet expected hydraulic and organic loadings. 	A2	<ul style="list-style-type: none"> (a) A <i>plant</i> shall be designed to treat waste generated by a minimum of 8 persons or up to a maximum of 20 persons and the design loading shall be stated; and (b) The application is accompanied by documentation meeting the requirements of Appendix 3.
P3	<p>The <i>plant</i> and any necessary ancillary equipment shall be designed to function and meet all other performance requirements during the <i>design life</i>.</p>	A3	<ul style="list-style-type: none"> (a) Each component of the <i>plant</i> and ancillary equipment will be manufactured to last the <i>design life</i> apart from mechanical and electrical components that - <ul style="list-style-type: none"> (i) have a minimum <i>design life</i> of 15 years; and (ii) minimum warranty period of 12 months; and (iii) are readily accessible for maintenance and replacement. (b) All components are capable of being securely fixed to withstand all loads encountered during transportation, installation and normal operation; and (c) The application is accompanied by documentation meeting the requirements of Appendix 3; and (d) The documentation in (c) will be publicly available for downloading during the <i>design life</i> from the website nominated in the application and on the label.
P4	<p>The <i>plant</i> is designed and constructed to -</p> <ul style="list-style-type: none"> (a) provide a reliable treatment process that will achieve the effluent quality criteria when operated and maintained in accordance with the manufacturer's instructions; and (b) provide easy access for authorised persons to all parts of the <i>plant</i> for inspection, maintenance and repairs which is secure from unauthorised access. 	A4	<ul style="list-style-type: none"> (a) The application is accompanied by documentation meeting the requirements of Appendix 3; and (b) The <i>plant</i> otherwise complies with the <i>applied provisions</i>.

Appendix 1 - Effluent Quality

Effluent Quality – Secondary

Secondary quality effluent must meet the following effluent compliance characteristics:

- (a) 90% of the samples taken over the test period must have a BOD₅ less than or equal to 20 g/m³ with no sample greater than 30 g/m³.
- (b) 90% of the samples taken over the test period must have total suspended solids less than or equal to 30 g/m³ with no sample greater than 45 g/m³.
- (c) Where disinfection is provided 90% of the samples taken over the test period must have a thermotolerant coliform count (determined by either the most probable number or membrane filter technique) not exceeding 200 organisms per 100 mL with no sample exceeding 1000 organisms per 100 mL.
- (d) Where chlorination is the disinfection process, the total chlorine concentration must be greater than or equal to 0.5 g/m³ and less than 2.0 g/m³ in four out of five samples taken.

Effluent Quality – Advanced Secondary

Advanced secondary quality effluent must meet the following effluent compliance characteristics:

- (a) 90% of the samples taken over the test period must have a BOD₅ less than or equal to 10 g/m³ with no sample greater than 20 g/m³.
- (b) 90% of the samples taken over the test period must have total suspended solids less than or equal to 10 g/m³ with no sample greater than 20 g/m³.
- (c) Where disinfection is provided 90% of the samples taken over the test period must have a thermotolerant coliform count (determined by either the most probable number or membrane filter technique) not exceeding 10 organisms per 100 mL with no sample exceeding 200 organisms per 100 mL.
- (d) Where chlorination is the disinfection process, the total chlorine concentration must be greater than or equal to 0.5 g/m³ and less than 2.0 g/m³ in four out of five samples taken.
- (e) Where the manufacturer has included nitrogen and/or phosphorus reduction in the treatment process, the effluent compliance criteria must be able to meet in addition to the above the following nutrient criteria:
 - (i) 90% of the samples, with 95% confidence limits taken over the test period shall have a total nitrogen concentration less than or equal to 10 mg/L.
 - (ii) 90% of the samples, with 95% confidence limits taken over the test period shall have a total phosphorus concentration less than or equal to 5 mg/L.

Comment: If the nitrogen and phosphorus concentrations do not meet the criteria nominated in paragraph (e) above, the manufacturer can request that recognition be given to the actual nitrogen and/or phosphorus concentration determined in the above evaluation by the Department of Infrastructure and Planning.

Appendix 2 - Performance Evaluation Testing – Other than AS/NZS 1546.3

Where AS/NZS 1546.3 does not apply (see examples mentioned previously) then performance evaluation testing may be carried out in accordance with the following clauses.

- (a) The test *plant* (including alarm system) must be installed on a premise that will produce either a flow of sewage or *greywater* representative of the operational loading. For a *greywater treatment plant* the source components must include all components e.g. bath, shower, basin, laundry and kitchen where applicable.
- (b) Aspects to consider when selecting and setting up a test site include:
 - Minimum flow requirements continually received over at least the 26 week monitoring program.
 - The premises are occupied full time and on a continual basis over the 26 week monitoring program.
 - *Greywater* influent to the *greywater treatment plant* is not to be absent for more than three consecutive days.
 - Appropriate diversion plumbing to either the sewer or other appropriate system line is made available in the case of *greywater treatment plant* failure.
 - Approval for installation and operation of the test site shall be obtained from the local government.
- (c) Raw sewage to the test *on-site sewage treatment plant* must not be pre-treated by chemical addition and should have characteristics within the following ranges.

Parameter	Characteristic
BOD ₅	150-300 mg/L
SS	150-300 mg/L
Total Nitrogen	20-100 mg/L
Total Phosphorus	6-25 mg/L

- (d) The test *plant* must be installed, commissioned, operated and maintained according to the manufacturer's instructions. The manufacturer is responsible for ensuring the *plant* is free of defects and is operable.
- (e) The *plant* must be placed under test over a period of twenty-six (26) weeks. The *plant* must be commissioned in accordance with the manufacturer's recommended procedure.
- (f) The following data must be obtained at the described intervals from grab samples collected over the 26-week monitoring period.

Parameter	On-site Sewage Treatment		<i>Greywater Treatment Plant</i>	
	Influent	Effluent	Influent	Effluent
Prescribed (must be analysed)				
BOD ₅	Every 12 days	Every 6 days	Every 12 days	Every 6 days
Total Suspended Solids (TSS)	Every 12 days	Every 6 days	Every 12 days	Every 6 days
Thermotolerant Coliforms *	Every 12 days	Every 6 days	Every 12 days	Every 6 days
Free Chlorine (where used)	N/A	Every 6 days	N/A	Every 6 days
Optional (Manufacturer to nominate)				
Total nitrogen	Every 12 days	Every 6 days	Every 12 days	Every 6 days
Total phosphorus	Every 12 days	Every 6 days	Every 12 days	Every 6 days

* If the *plant* does not include disinfection then thermotolerant coliforms can be excluded from the monitoring program.

- (g) Other data to be recorded at a minimum of every 6 days includes -
- *Plant* inflow reading.
 - Site notes and comments.
- (h) The final effluent grab samples must be taken from the outlet chamber or a point prior to land application. The influent samples must be taken upstream of all process units associated with the built item or *greywater treatment plant*.
- (i) The samples for BOD₅, total suspended solids, total nitrogen, total phosphorus and thermotolerant coliforms taken by the testing agency must be directly transported and delivered to a laboratory, registered by NATA to carry out analyses for the parameters specified. Analyses for disinfectant concentration must be tested on-site immediately after sampling.

The manufacturer must ensure that the premises are returned to their original condition, or to the satisfaction of the owner of the premises and the local government once testing has been completed.

Appendix 3 - Documentation

The following must be produced and submitted with the application.

Drawings

Three copies of drawings must be provided in A3 format. They must be full engineering drawings to scale and dimensioned, contain a full listing of all components with name, model, size, description, function, material of manufacture and location in the *plant* and include any wiring diagrams.

The components to be shown must include the electric motor(s), gearbox, compressor, pump(s), valves, diffusers, media, pipework, scum collection and sludge pumping equipment, brackets, electrodes, float switches, control panel and the arrangement of the alarm.

Owner's Manual and label

Each *plant* must be accompanied by an owner's manual prepared by the manufacturer. Each *plant* must have securely affixed to it a label designed to last for the *design life* showing items (a), (b) and (c) below.

The authorised representative must provide the manual to the owner at the time of the *plant* and ancillary equipment installation or on occupation of the premises. The manual must be written so that it can be easily understood by the intended reader and must include at a minimum -

- (a) The *plant's* model designation.
- (b) The name and telephone number of an appropriate service representative to be contacted in the event that a problem with the *plant* occurs.
- (c) The website from which the documentation can be downloaded during the *design life*.
- (d) A statement confirming that the *plant* meets the requirements of this Code.
- (e) A clear statement of examples of the types of waste that can be effectively treated by the *plant*.
- (f) A list of household substances that, if discharged to the *plant*, may adversely affect the *plant*, the process, or the environment.
- (g) Comprehensive operating instructions that clearly delineate proper function of the *plant*, operating and maintenance responsibilities of the owner and authorised service personnel, and service-related obligations of the manufacturer or facility builder.
- (h) Requirements for the periodic removal of sludge from the *plant*.
- (i) A course of action to be taken if the *plant* is to be used intermittently or if extended periods of non-use are anticipated.
- (j) Detailed methods and criteria to be used to identify *plant* malfunction or problems.
- (k) A statement instructing the owner to reference the label in the event that a problem arises or service is required.

Installation Manual

Manufacturers must provide comprehensive and detailed installation instructions to authorised representatives. The manual must be written so that it can be easily understood by the intended reader and must include as a minimum -

- (a) A numbered list of *plant* components and an accompanying illustration, photograph, or print in which the components are respectively identified.
- (b) Design, construction, and material specifications for the *plant's* components.
- (c) Wiring schematics for the *plant's* electrical components.
- (d) Off-loading and unpacking instructions including safety considerations, identification of fragile components and measures to be taken to avoid damage to the *plant*.
- (e) A process overview of the function of each component and the expected function of the entire *plant* when all components are properly assembled and connected.
- (f) A clear definition of *plant* installation requirements including plumbing and electrical power requirements, ventilation, air intake protection, bedding, hydrostatic displacement protection, water tightness, slope and miscellaneous fittings and appurtenances.
- (g) Repair or replacement instructions in the event that a *plant* possesses flaws that would inhibit proper functioning and a list of sources where replacement components can be obtained.
- (h) A detailed start-up procedure.

Operation and Maintenance Manual

Manufacturers must provide comprehensive and detailed operation and maintenance instructions to authorised service personnel. The manual must be written so that it can be easily understood by the intended reader and shall include at a minimum -

- (a) A maintenance schedule for all components.
- (b) Requirements and recommended procedures for the periodic removal of sludge from the *plant*.
- (c) Recommended methods for collecting effluent samples.
- (d) The expected effluent produced by the operational system.

Part 6 – Non *certified* testable backflow prevention devices for fire service

	CRITERIA PERFORMANCE		ACCEPTABLE SOLUTIONS
P1	Fire services connected to <i>water service provider's</i> infrastructure have an appropriate testable backflow prevention device installed.	A1	Fire services connected to <i>water service provider</i> infrastructure have a – a) <i>certified</i> testable backflow prevention device; or b) non <i>certified</i> testable spring loaded single check valve.
P2	Installed testable backflow prevention devices have appropriate isolating valves and are fitted for easy removal.	A2	A testable backflow prevention device– a) has resilient-seated isolating valves located immediately upstream and adjacent to the device; and b) is fitted in an accessible position; and c) is connected with either flange or barrel union fittings for easy removal and replacement; and d) locked in the open position; and e) otherwise complies with the <i>applied provisions</i> .

Appendix 4 – Field testing of testable single check valves

Scope

This appendix sets out the method for field testing of testable single check valves.

Apparatus

A test kit as shown in Figure 1

Procedure

The procedure shall require all measurements to be taken at ambient air temperature;

- (a) with reference to Figure 2 check/open USIV (3); and
- (b) in sequence open and close test taps (1) and (2) to flush out any impurities; and
- (c) close DSIV (4).

To test the non-return valve

- (a) close test kit valves (A) and (B) and open test kit valve (C) and connect;
 - (i) the high pressure hose of the test kit to test tap (1); and
 - (ii) the low pressure hose of the test kit to test tap (2).
- (b) open test taps (1) and (2); and
- (c) open test kit valve (A) and bleed water through the vent valve (C); and
- (d) close the test kit valve (A); and
- (e) slowly open the test kit valve (B) and bleed water through the vent valve (C); and
- (f) slowly close test kit valve (B) and observe and record the reading on the differential pressure gauge; and

NOTE: A reading below 7kPa indicates a faulty non-return valve.

- (g) close test taps (1) and (2), open test kit valves (A) and (B), disconnect the test kit, close the test kit valve (B).

To test the upstream and downstream isolating valves

- (h) connect the high pressure hose to test tap (2); and
- (i) bleed the high pressure hose to test tap (2); and
- (j) in sequence close –
 - (i) test kit valve (C); and
 - (ii) USIV (3); then
- (k) slowly open the test kit valve (B); until the pressure on the gauge drops by approx 10 kPa; then
- (l) close test kit valve (B); then

NOTE: Observe the reading on the differential pressure gauge.

- a rise in pressure on the gauge indicates a leaking USIV (3)
- a drop in pressure on the gauge indicates a leaking DSIV (4)

- (m)
 - (i) close test tap (2); and
 - (ii) open test kit valve (B); and
 - (iii) disconnect high pressure hose from test tap (2); and
 - (iv) open isolating valves (3) and (4).

(This restores the device to operating condition)

(Lock USIV and DSIV in open position)

Test report

The following shall be reported:

- (a) the reading obtained in step (f).
- (b) whether the USIV and DSIV are tight.

Criteria for acceptance

The following shall be criteria for acceptance:

- (i) the reading in step (f) shall be not less than 7kPa; and
- (ii) the USIV shall be tight; and
- (iii) the DSIV shall be tight.

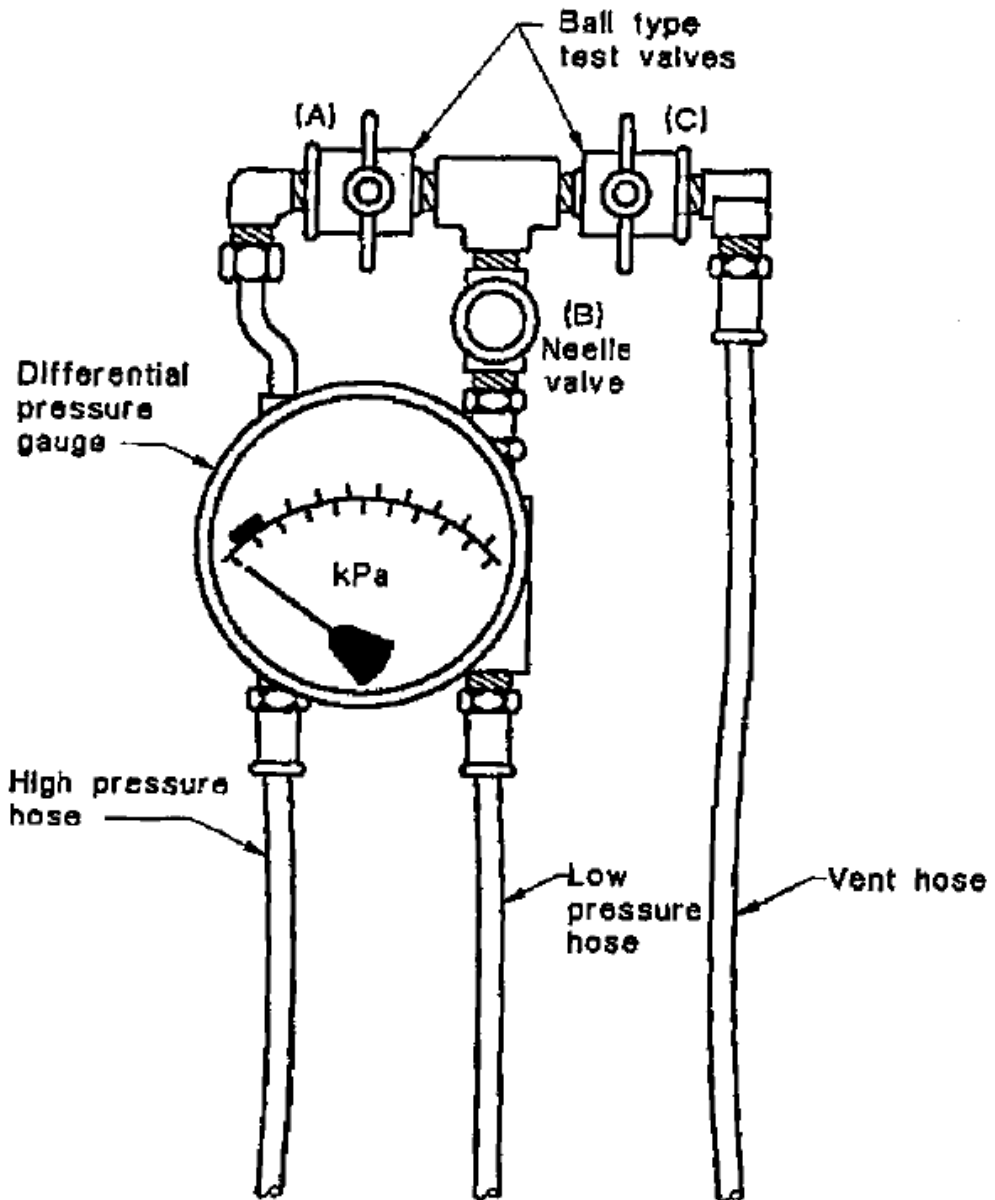

Figure 1 – Typical test kit *apparatus*

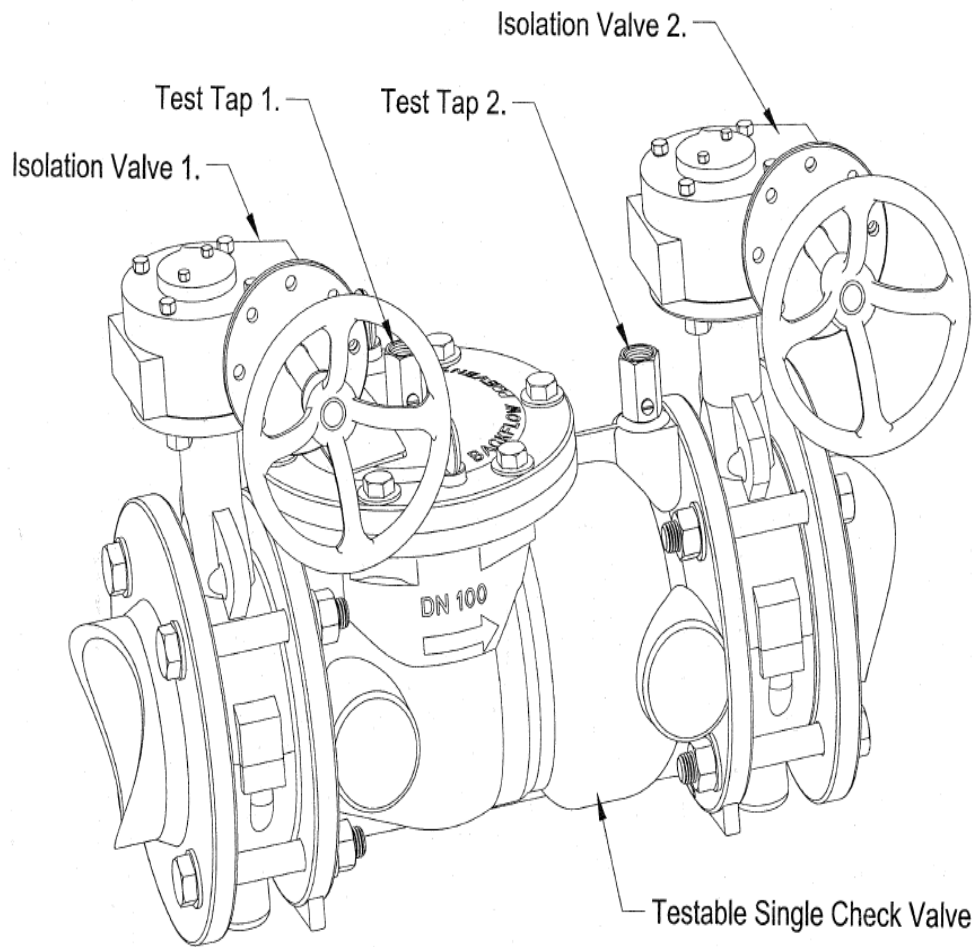

Figure 2- Typical Arrangement Testable single check valve fire service assembly

Part 7 – New and replacement electric hot water systems

	PERFORMANCE CRITERIA		ACCEPTABLE SOLUTIONS
P1	<p>Hot water systems with a low greenhouse gas emissions impact are installed –</p> <p>(a) for <i>new class 1 buildings</i>; and</p> <p>(b) at replacement of <i>existing hot water systems</i> for <i>class 1</i> buildings from 1 January 2010.</p>	A1	<p>(1) In <i>new class 1 buildings</i> hot water is supplied by –</p> <p>(a) a heat pump or a solar hot water system that is eligible to receive:</p> <p>(i) in a building with 3 or more bedrooms, at least 22 Renewable Energy Certificates; or</p> <p>(ii) in a building with less than 3 bedrooms, at least 14 Renewable Energy Certificates; or</p> <p>(b) gas hot water system with an energy rating of at least five stars.; and</p> <p>(2) From 1 January 2010, replacement of <i>existing hot water systems</i> for <i>class 1</i> buildings hot water is supplied by a –</p> <p>(a) solar hot water system; or</p> <p>(b) heat pump; or</p> <p>(c) gas hot water system with an energy rating of at least five stars.</p> <p>Note: Renewable Energy Certificates are issued under the Commonwealth Government’s Mandatory Renewable Energy Target.</p>
P2	<p>From 1 January 2010, the supply of hot water, may be maintained to the <i>class 1</i> building for a short period by a <i>temporary hot water system</i> before the installation of the <i>replacement hot water system</i>.</p>	A2	<p>From 1 January 2010, a <i>temporary hot water system</i> may be used to supply hot water to a <i>class 1</i> building for a maximum of 60 calendar days from the date the <i>temporary hot water system</i> was installed.</p>
P3	<p>Hot water systems are installed are in a location to reduce the amount of cold water drawn off any tap in the <i>common bathroom</i> before hot water commences to flow for –</p> <p>(a) <i>new class 1 buildings</i>; and</p> <p>(b) <i>class 1</i> buildings for <i>replacement hot water systems</i> after 1 January 2010.</p>	A3	<p>Hot water systems are installed as close as practicable to the building’s <i>common bathroom</i> for –</p> <p>(a) <i>new class 1 buildings</i>; and</p> <p>(b) <i>class 1</i> buildings for <i>replacement hot water systems</i> after 1 January 2010.</p>

Part 8 – Water conservation for *class 1* and *class 2* buildings

	PERFORMANCE CRITERIA		ACCEPTABLE SOLUTIONS
P1	For lots which have a <i>class 1</i> or <i>class 2</i> building, in areas serviced by a <i>water service provider</i> , <i>outdoor irrigation systems</i> installed or replaced on or after 1 March 2009 must facilitate the efficient use of water.	A1	For lots which have a <i>class 1</i> or <i>class 2</i> building, in areas serviced by a <i>water service provider</i> , <i>outdoor irrigation systems</i> installed or replaced on or after 1 March 2009 comply with Queensland Water Commission guidelines for an <i>efficient irrigation system</i> - 'Efficient Irrigation for Water Conservation' when: <ul style="list-style-type: none"> (a) connected to a <i>water service</i>; or (b) connected to a <i>rainwater tank</i> where the <i>rainwater tank</i> has a continuity of supply from a <i>water service</i> through either: <ul style="list-style-type: none"> (i) a <i>trickle top-up system</i> ; or (ii) an <i>automatic switching device</i> where the off take is located downstream of the <i>automatic switching device</i>.

Part 9 – Chief Executive Approval for *Blackwater* Trials in Southeast Queensland

Definitions

This Part establishes the requirements for a Chief Executive Approval for the installation of an *on-site sewage treatment plant* for testing purposes only in a sewered area in the South East Queensland (SEQ) Region. *The Plumbing and Drainage Act 2002* (PDA) permits the installation for testing purposes only in *class 2, 5, 6 and 9b*.

A Chief Executive Approval does not include:

- a) the method of land application of the treated effluent; or
- b) a chemical, composting or incinerating toilet; or
- c) a *dry-vault toilet* (e.g. waterless toilet).

Testing Agency

All compliance checking, monitoring, testing, and sampling is to be performed by an agency accredited as a third party quality management certification body certified by the Joint Accreditation System of Australia and New Zealand (JAS-ANZ) or by another accreditation body with which JAS-ANZ has a memorandum of understanding, and at the cost of the applicant.

The samples for Biochemical Oxygen Demand (BOD₅), suspended solids, total nitrogen, total phosphorus and thermotolerant coliform, taken by the testing agency, must be directly transported and delivered to a laboratory, registered by the National Association of Testing Authorities (NATA) to carry out analyses for the parameters specified.

Applicable residual disinfectant and dissolved oxygen samples must be analysed on site. The test criteria and test period procedures specified in the Guideline for Treated Blackwater Reuse Trials (the guideline).

Water quality specifications for the treated blackwater trials can be found in Table 9.1.

Performance Criteria for Chief Executive Approvals for *Blackwater* Trials

	PERFORMANCE CRITERIA		ACCEPTABLE SOLUTIONS
P1	To protect public health by ensuring that— (a) all plant discharges are safe; and (b) risks associated with the discharge of human waste and domestic-wastewater to the environment are minimised.	A1	The <i>plant</i> which is an <i>on-site sewage treatment plant</i> - (a) meets the Effluent Quality requirements in Table 9.1; (b) meets the requirements of Appendix 9B; and (c) otherwise complies with the <i>applied provisions</i> .
P2	To maintain and enhance the quality of the environment by ensuring that— (a) surface and groundwater are not polluted; and (b) soil productivity is maintained or enhanced, and cumulative adverse environmental effects do not occur during the <i>design life</i> ; and (c) The relationship between input and output within a hydrological system is correct for the volumes of <i>blackwater</i> produce.	A2	The <i>plant</i> which is an <i>on-site sewage treatment plant</i> - (a) complies with the Effluent Quality requirements in Table 9.1; and (b) otherwise complies with the <i>applied provisions</i> .
P3	To maintain and enhance community <i>amenity</i> by ensuring that the <i>plant</i> — (a) is managed so as to achieve sustainable long-term performance; (b) is designed to enhance the <i>amenity</i> ; and (c) provides treatment capacity to meet expected hydraulic and organic loadings.	A3	(a) A <i>plant</i> shall be designed to treat waste generated onsite and the design loading shall be stated; (b) The application is accompanied by documentation meeting the requirements of Appendix 9B; and (c) Otherwise complies with the <i>applied provisions</i> .
P4	The system shall be designed to function and meet all other performance requirements during the <i>design life</i> .	A4	(a) Each component of the system will be manufactured to last the <i>design life</i> apart from mechanical and electrical components that — (i) have a minimum <i>design life</i> of 15 years; (ii) minimum warranty period of 12 months; (iii) are readily accessible for maintenance and replacement. (b) All components are capable of being securely fixed to withstand all loads encountered during transportation, installation and normal operation; (c) The application is accompanied by documentation meeting the requirements of Appendix .9A; (d) The documentation in (c) will be publicly available for downloading during the design life from the website nominated in the application and on the label; and (e) The system otherwise complies with the <i>applied provisions</i> .
P5	The <i>plant</i> is designed and constructed to – (a) provide a reliable treatment process that will achieve the effluent quality criteria when operated and maintained in accordance with the manufacturer's instructions; and (b) provide easy access for authorised persons to all parts of the <i>plant</i> for inspection, maintenance and repairs which is secure from unauthorised access.	A5	(a) The application is accompanied by documentation meeting the requirements of Appendix 9A; and (b) The <i>plant</i> otherwise complies with the <i>applied provisions</i> .

TABLE 9.1: WATER QUALITY SPECIFICATIONS FOR TREATED BLACKWATER TRIALS.

All analysis must be done by a laboratory NATA accredited for the particular parameter. If water is over the maximum value at any time, it must be disposed off to sewer while the reasons are investigated. If water that is over the maximum value for any parameter has already been used on-site, then DIP and QH must be notified via the form in Attachment 7 (of the guideline).

Parameter (Mandatory)	Standard (95% of samples must comply)	Maximum	Monitoring Frequency³	Sampling point
E.coli	<1 cfu/100ml	<10 cfu/100ml	Weekly (triplicate samples)	End of treatment process
<i>Clostridium perfringens</i>	<1 cfu/100ml	<10 cfu/100ml	Weekly	End of treatment process
F-RNA bacteriophages ²	<1 pfu/100ml	<10 pfu/100ml	Weekly	End of treatment process
Somatic coliphages ²	<1 pfu/100ml	<10 pfu/100ml	Weekly	End of treatment process
Turbidity	<2 NTU	5 NTU	On-line or daily	Before disinfection point
Chlorine residual (mandatory for toilet flushing)	0.2 – 1.0 mg/L residual after a minimum contact time of 30 minutes	0.2 mg/L (minimum)	On-line or daily	Point of use or in storage tank
pH	6 – 8.5		On-line or daily	Where applicable in treatment process
Gross gamma radiation ¹	<5 Bq/L	5 Bq/L	On-line	End of treatment process
Research Parameters (Mandatory sampling, however column 2 values are guideline values only)				
Total Dissolved Solids/Electrical conductivity ⁴	<1000 mg/L/<1600µS/cm	No maximum for research parameters	Weekly	End of treatment process
Total Nitrogen	No guideline value		Monthly	End of treatment process
Total Phosphorus	No guideline value		Monthly	End of treatment process

¹People undergoing radiotherapy procedures have the potential to excrete material that is high in radioactivity. Due to smaller dilution levels in *blackwater* sewage systems and the possibility of cross connections between the treated *blackwater* system and the potable drinking water system, this issue needs to be managed properly to protect public health. If water is found to contain greater than 5 Bq/L gross gamma radiation, it should be disposed of to sewer immediately.

²Phage testing may be reduced from weekly to monthly following advice from the multi-agency committee, if validation report has found them to be non-detectable.

³For the parameters measured on-line, a quality control sample should be sent to a NATA registered laboratory as part of a quality control program, to ensure accuracy of on-line equipment.

⁴Either total dissolved solids or electrical conductivity can be analysed.

Appendix 9A – Documentation for *Blackwater* Trials

Documentation

The following must be produced and submitted with the application.

Drawings

Three copies of drawings must be provided in A3 format. They must be full engineering drawings to scale and dimensioned, contain a full listing of all components with name, model, size, description, function, material of manufacture and location in the *plant* and include any wiring diagrams.

The components to be shown must include the electric motor(s), gearbox, compressor, pump(s), valves, diffusers, media, pipework, scum collection and sludge pumping equipment, brackets, electrodes, float switches, control panel and the arrangement of the alarm.

Installation Manual

Each *plant* must be accompanied by an owner's manual prepared by the manufacturer. Each *plant* must have securely affixed to it a *label* designed to last for the *design life* showing items (a), (b) and (c) below.

The authorised representative must provide the manual to the trial participant at the time of system installation or on occupation of the premises. The manual must be written so that it can be easily understood by the intended reader and must include at a minimum -

- (a) A numbered list of treatment plant components and an accompanying illustration, photograph, or print in which the components are respectively identified;
- (b) Design, construction and material specification for the treatment plant components;
- (c) Wiring schematics for the treatment plant electrical components;
- (d) Off-loading and unpacking instructions including safety considerations, identification of fragile components and measures to be taken to avoid damage to the treatment plant;
- (e) A process overview of the function of each component and the expected function of the entire treatment plant when all components are properly assembled and connected;
- (f) A clear definition of the treatment plant installation requirements including plumbing and electrical power requirements, ventilation and air intake protection;
- (g) Displacement protection, water tightness, slope and miscellaneous fittings and appurtenances;
- (h) Repair or replacement instructions in the event that a treatment plant possesses flaws that would inhibit proper functioning and a list of sources for replacement components; and
- (i) A detailed start-up procedure.

Operation and Maintenance Manual

Manufacturers must provide comprehensive and detailed operation and maintenance instructions to authorised service personnel. The manual must be written so that it can be easily understood by the intended reader and shall include at a minimum -

- (a) Description and schematic of the treatment system that depicts the treatment process, including the flow of water, treatment components, pumps, compressors, valves, pipework;
- (b) Source water characterisation and hazards identified in the source water and the expected function of the entire treatment plant for removing hazards from source water; possible hazards in the source water;
- (c) Identification of critical control points and critical limits for the parameters used to assess critical control points. For example if filtration is a critical control point for effective disinfection turbidity from the source water. High turbidity of over 5 NTU is a breach of the critical limit indicating the critical control point is not functioning effectively. An alarm should therefore be generated when turbidity is over 5 NTU to warn the operator of a potential problem with the treatment process);
- (d) Water quality monitoring programs;
- (e) Operation instructions for the WTS (including manuals for all the components of the system). Operating instructions should be comprehensive and clearly delineate proper function of the treatment system and the operating and maintenance responsibilities of the owner and authorised service personnel, and the service-related obligations of the manufacturer or facility builder;
- (f) Proposed volumes of treated blackwater to be produced;
- (g) Proposed storage times;
- (h) Approximate usage figures (volumes of treated blackwater used) for each use;
- (i) A maintenance schedule for all components and equipment (including sludge removal);
- (j) Investigation procedure for monitoring biofilm build up in pipe work and a schedule for biofilm control such as but not limited to, pipe scouring;
- (k) A calibration schedule for all relevant components and any laboratory equipment on-site;
- (l) Recommended methods for collecting, preserving, storing and transporting samples to a laboratory which is NATA registered for the relevant analyses;
- (m) Disposal methods for any waste produced through the treatment process or out of specification water;
- (n) Workplace Health and Safety procedures for storage of chemicals and other relevant activities;
- (o) Waste disposal procedures for any liquid or solid waste from the WTS site;
- (p) Incident procedures if plant malfunctions while operating unattended;
- (q) Notification procedures if out of specification water is used on-site;
- (r) The plants model designation;

- (s) The name and telephone number of an appropriate service representative to be contacted in case of problems;
- (t) A statement confirming that the WTS meets the requirements of the QPW code;
- (u) Register to record the types of breakdowns, how the operator knows a breakdown has occurred, reaction times and actions to rectify problems that occur in the treatment system and reticulation system. This register must also record replacement of equipment. Over the life of the trial record the amount of time that the plant was not operational due to failures over the life of the trial;
- (v) Register to record the amount of time the operator has to spend daily/weekly in overseeing the operation of the WTS. Include in this register which areas of operation take up most of the operators' time;
- (w) Register to document the costs associated with the project;
- (x) Operators' qualifications and knowledge of the WTS;
- (y) Documented results of the ongoing consultation process; and
- (z) Documented results of the ongoing educational process.

Appendix 9B Conditions of Approval for *Blackwater* Trials

Validation of treatment process

The Treated Blackwater Reuse Trials Guide contains further information on validation methods and must be used in conjunction with this section of the Code.

1. Validation of treatment process **(Mandatory)**
 - Results from pre-commissioning validation and commissioning validation, methodologies and results; and
 - Results from commissioning verification (minimum of 20 sampling events must be taken within 6 months. Each sampling event must be on a different day. These samples need to be analysed at a NATA accredited laboratory for the parameters in *Table 9.1* and comply with the corresponding values in column 2 and 3 of *Table 9.1*) *E. coli* samples must be taken in triplicate.
2. Validation of On-line monitoring **(Mandatory)**
 - All on-line monitoring equipment needs to be validated as per the manufacturer's instructions. Validation methods and any results must be included in the validation report; All on-line monitoring equipment needs to be calibrated as per the manufactures instructions; and
 - Calibration results must be included in the validation report.
3. Validation of Storage of *blackwater* (Only applicable if water is stored for more than 24 hours anytime throughout the trial).
 - If treated *blackwater* is to be stored on-site for longer than 24 hours during the *blackwater* reuse trial, then during the validation period it must be demonstrated that the quality of the water is not degraded during storage; The way this is done is up to the proponent but some suggestions include:
 - a) Sampling water to ensure it still meets the parameters in *Table 9.1* after various storage times that correspond to those that may occur during the operational phase of the trial;
 - b) Monitoring any process employed to retain the water quality (e.g. chlorination of the storage tank); and
 - Methods and results from the validation of the storage of treated *blackwater* must be included in the validation report.
4. Cross-connection (Only applicable if water is plumbed back into building structure for toilet flushing or irrigation systems).
 - If use of effluent could result in a cross-connection with the potable water system, then the methods to control this must be included in the validation report.
5. Operational Manual **(Mandatory)**
 - A copy of the operational Manual will need to accompany the validation report. The operations manual must include all relevant information from *Appendix 6* of the guidelines.

Table T1A – Potential end uses of *greywater* where a *greywater treatment plant* is installed on premises generating less than 3kL (<3kL) per day

Potential End Uses	Parameter	Effluent Compliance Value
End uses with a high level of human contact, including: <ul style="list-style-type: none"> Sanitary flushing Laundry use (cold water source to washing machines) Vehicle washing Path/Wall washdown 	Biochemical oxygen demand (BOD5) Total suspended solids (TSS) Thermo-tolerant organisms (org/100ml) pH Turbidity Disinfection	≤10 mg/L ≤10 mg/L <10 6.5 – 8.5 <2 NTU (95%ile) / <5 NTU (maximum) Cl: 0.2 – 1.0 mg/L residual (where used as primary disinfection)
End uses with a medium level of human contact, including: Lawn and garden spray irrigation	Biochemical oxygen demand (BOD5) Total suspended solids (TSS) Thermo-tolerant organisms (org/100ml) pH Turbidity Disinfection	≤20 mg/L ≤30 mg/L <30 6.5 – 8.5 <5 NTU (95%ile) Cl: 0.2 – 1.0 mg/L residual (where used as primary disinfection)
End uses with a low level of human contact, including: <ul style="list-style-type: none"> Lawn and Garden manual bucketing, surface broadcasting, sub-surface irrigation 	Biochemical oxygen demand (BOD5) Total suspended solids (TSS) Thermo-tolerant organisms (org/100ml) pH Disinfection	≤240 mg/L ≤180 mg/L N/A N/A N/A

Table T1B – Potential end uses of *greywater* where a *greywater treatment plant* is installed on premises generating greater than 3kL (>3kL) per day

Potential End Uses	Parameter	Effluent Compliance Value
End uses with a high level of human contact, including: <ul style="list-style-type: none"> Sanitary flushing Laundry use (cold water source to washing machines) Vehicle washing Path/Wall washdown 	Biochemical oxygen demand (BOD5) Total suspended solids (TSS) Escherichia coli (95% of samples taken over a 12 month period) Escherichia coli (maximum) pH Turbidity Disinfection (where chlorine is used as primary disinfection) (residual must be maintained at point of use for sanitary flushing and laundry use)	≤10 mg/L ≤10 mg/L <1 cfu/100ml 10 cfu/100ml 6.5 – 8.5 <1 NTU (95%ile) / 5 NTU (maximum) Cl: 0.2 – 1.0 mg/L residual
End uses with a medium level of human contact, including: <ul style="list-style-type: none"> Lawn and garden spray irrigation 	Biochemical oxygen demand (BOD5) Total suspended solids (TSS) Escherichia coli (95% of samples taken over a 12 month period) Escherichia coli (maximum) pH Turbidity	≤10 mg/L ≤10 mg/L <10 cfu/100ml <100 cfu/100ml 6.5 – 8.5 <5 NTU (95%ile)
End uses with a low level of human contact, including: <ul style="list-style-type: none"> Lawn and Garden drip or sub-surface irrigation (no pooling on surface) 	Biochemical oxygen demand (BOD5) Total suspended solids (TSS) Escherichia coli (95% of samples taken over a 12 month period) Escherichia coli (maximum)	≤20 mg/L ≤30 mg/L <100 cfu/100ml <1000 cfu/100ml

Table T2 - Estimate of *greywater* generated by an average house in a sewerred area (3-bedroom home and four occupants)

<i>Greywater flow</i>	Litres/person/day
Daily <i>greywater</i> flow from bathroom	60
Daily <i>greywater</i> flow from laundry	35
Total for bathroom and laundry	95

Table T3 - Estimate of *greywater* generated by an average house in an unsewered area

<i>Greywater flow total for bathroom and laundry</i>	Bedrooms	Litres/ day
1-5	3	600
6-7	4	840
8	5	960
9-10	6	1200

Table T4 - Setback distances for subsurface *land application* area for a *greywater treatment plant* or an *on-site sewage treatment plant*

Feature	Horizontal Separation Distance (metres)		
	Up slope	Down slope	Level
Distance from the edge of trench/bed excavation or subsurface irrigation distribution pipework to the nearest point of the feature			
Property boundaries, pedestrian paths, footings of buildings, walkways, recreation areas, retaining wall footings.	2	4	2
In ground swimming pools.	6	6	6
In ground potable water tank.	6 *	6 *	6 *

*Note: For Primary effluent the distance from an in-ground potable water tank must be 15 metres.

Table T5 - Setback distances for surface irrigated *land application* area for a *greywater treatment plant* or an *on-site sewage treatment plant*

The separation distances are based on a spray plume with a diameter not exceeding 1 m or a plume height not exceeding 0.3 m above the finished surface level. Distances are given in metres from the edge of the irrigated wetted area to any point of the feature.

Feature	<i>Horizontal Separation Distance (metres)</i>
Property boundaries, pedestrian paths and walkways.	2
Water edge of a swimming pool.	6
Dwellings, recreation areas.	10*

* Note: For Primary effluent the distance from an in-ground potable water tank must be 15 metres.

Table T6 - Setback distances from a *greywater diversion device*

Feature	Setback Distance (metres)
Property boundaries, pedestrian paths, and driveways.	1.0
Footings of buildings.	1.5
Retaining wall footing.	1.0
In ground swimming pool surrounds.	1.0
In ground potable water tank.	6.0
Bores intended for human consumption.	50

**Table T7 - Setback distances for *on-site sewerage facilities* and *greywater use facilities*
(Protection of surface water and groundwater)**

Feature	Separation	Distance	(metres)
For onsite – see Appendix 1	Advanced Secondary	Secondary	Primary*
For <i>greywater</i> – see T1A or T1B	High	Medium	Low
Top of bank of permanent water course; or Top of bank of Intermittent water course; or Top of bank of a lake, bay or estuary or, Top water level of a surface water source used for agriculture, aquaculture or stock purposes or; Easement boundary of unlined open stormwater drainage channel or drain. Bore or a dam used or likely to used for human and or domestic consumption	10	30	50
Unsaturated soil depth to a permanent water table (vertically)	0.3	0.6	1.2

* Note: Primary effluent typically has a BOD (Biochemical Oxygen Demand) of between 120 -240 mg/L and Total Suspended Solids of between 65 -180 mg/L.